

FEATURES

- ✓ 100% water saving - saves up to 300L of water per test
- ✓ Accurately represents 1 sprinkler head in operation
- ✓ Consistent flow rate – irrespective of system pressure
- ✓ No fire pumps operate
- ✓ No brigade isolation required during tests*
- ✓ No new oxygenated water is introduced into the system
- ✓ Saves time during testing
- ✓ Prevents pressure fluctuations during test
- ✓ No drain required
- ✓ Meets requirements of AS2118

* Assuming pressure switch only is calling brigade.

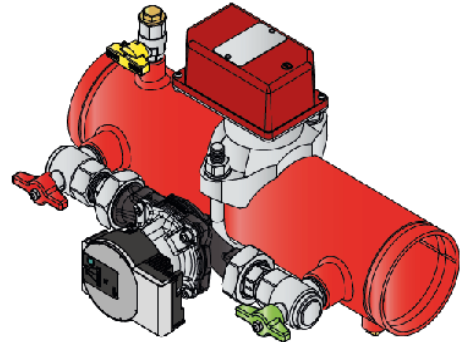

PRODUCT DESCRIPTION

Zonecheck is a remote flow-switch testing device. It works by using a closed loop system that re-circulates water to simulate sprinkler head operation and tests the flow-switch without discharging water.

AS1851 requires flow-switches installed in a sprinkler system to be tested 6 monthly (FM Global requires this test monthly). During a traditional flow-switch test, water is discharged from the down stream end of the pipe. This pressure difference across the flow-switch generates a water flow causing the flow switch to operate. The unique Zonecheck system is the modern way to carry out this important test quickly, efficiently and inexpensively with zero water wastage.

Zonecheck provides a true and accurate test of the flow-switch and compared with a traditional test solenoid/drain arrangement saves up to 300 litres of water per test (dependant on flow-switch retard setting). The Zonecheck pump has a flow control orifice which accurately represents just one sprinkler head in operation, irrespective of current system pressure, which is the only true way to test the effective operation of a flow-switch with one sprinkler head operating.

As no water is discharged from the system, the system pressure remains unchanged, therefore no fire pumps operate and there is no need to perform pressure switch/brigade isolations or recharge the system before during or after the tests. This makes testing a much simpler process than any other method so tests can easily be performed on a more regular basis with no system interruption while ensuring correct system operation at all times.

Zonecheck is simple and easy to install and comes as a complete pressure tested unit with pump, flow switch, and pipe with rolled groove ends for ease of installation. Retrofit and LiveTap versions are also available for existing installations.

Zonecheck is the best solution for 100% water saving on flow-switches and meets all requirements of AS2118 and AS1851.

Note: This is an indent item, lead times of up to 4-6 weeks may apply.

TECHNICAL SPECIFICATIONS

ZONECHECK

Working Pressure Rating	12 bar (175 PSI) max
Compatible Pipe	50, 65, 80, 100, 150 & 200mm
Connections	Rolled groove (both ends)
Installation	Horizontal/vertical

FLOW-SWITCH

Triggering flow-rate	30-57 litres/minute
Enclosure Rating	IP54
Conduit Entrances	Ø22.2mm
Contact Ratings	10A @ 125/250VAC 2.5A @ 24Vdc
Operating temperature	0-68°C

PUMP

Operating Voltage	240V 50Hz WILO PARA
Full Load Current	0.82
Power Rating	75W
Operating Temperature	0-68°C
IP Rating	IPX4D
WP Rating	175 psi

KEY-SWITCH

Operating Voltage	Single Phase 240V-50Hz
Key-Switch Operating Modes	Self-test: Wired locally; Group test: Interconnected
Key-Switch LED Operation	Ready state: No LED
Test Initiation	Pump Running LED (green)
Flow-Switch Activation	Flow switch Activated LED (green)
Full Load Current	0.82A
Power Input (P1)	75W

ORDERING INFORMATION

ZC-50L/RHXKS	Zonecheck (left or right flow) 50mm (includes FlowSwitch)
ZC-65L/RHXKS	Zonecheck (left or right flow) 65mm (includes FlowSwitch)
ZC-80L/RHXKS	Zonecheck (left or right flow) 80mm (includes FlowSwitch)
ZC-100L/RHXKS	Zonecheck (left or right flow) 100mm (includes FlowSwitch)
ZC-150L/RHXKS	Zonecheck (left or right flow) 150mm (includes FlowSwitch)

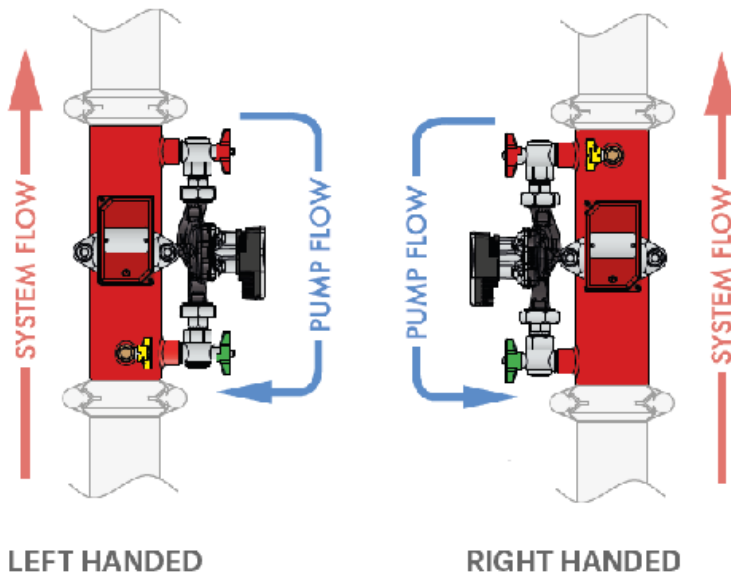

* As the pump is a recirculation pump, the pump direction is always in the opposite direction to sprinkler flow.

DIMENSIONS

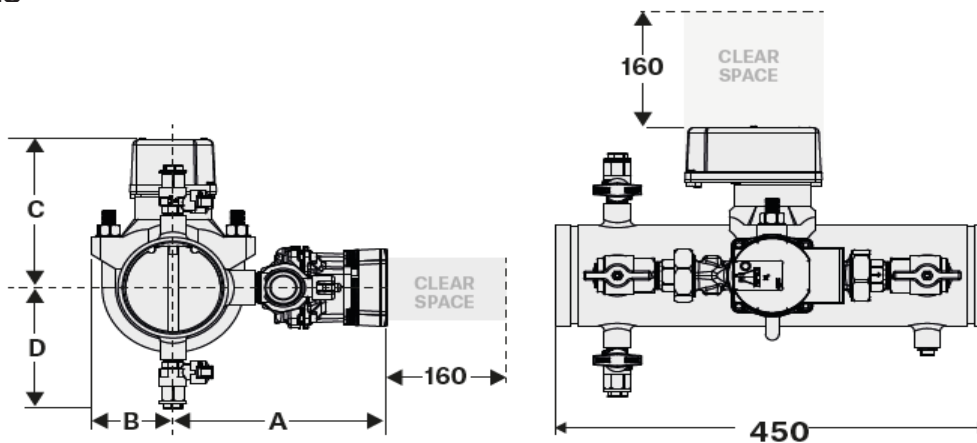

ØIN	ØMM	A	B	C	D
2"	50	210	66	145	116
2½"	65	215	66	155	124
3"	80	220	85	165	130
4"	100	225	85	170	140
6"	150	250	115	195	170
8"	200	275	150	225	195

FLOW-SWITCH WIRING

Typical fire-alarm/flow-switch connection (typical arrangement only). Refer to specific fire-alarm panel manufacturer instructions for end of line resistor monitoring.

X = fire/alarm (refer to panel manufacturer)
y = end of line resistor (refer to panel manufacturer)

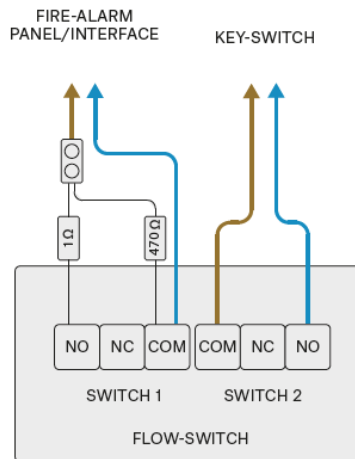
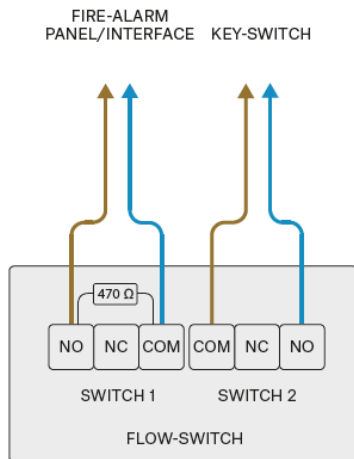

ORIENTATION

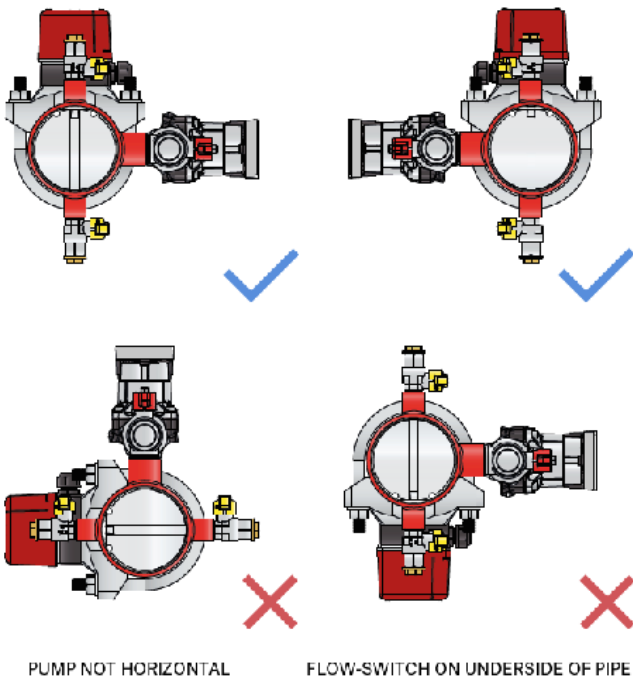

TYPICAL CONNECTION

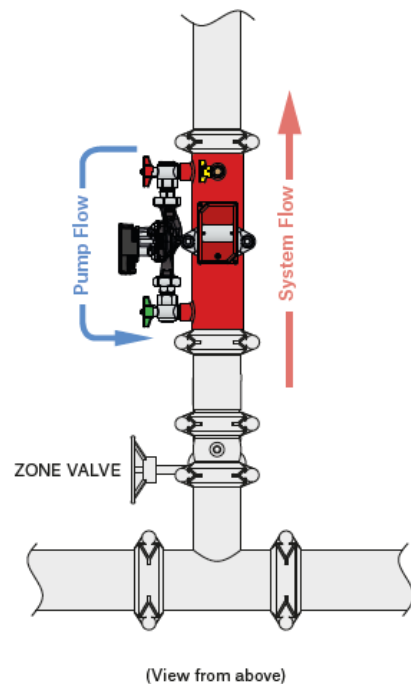

VENTING

Zonecheck will not work properly if air is trapped within the unit. Follow these simple steps to vent trapped air:

1. Notify building management of your actions
2. Isolate alarms & main fire pump
3. Have a suitable container or drain ready to catch any water
4. Remove the vent plug from the uppermost yellow vent-valve on the Zonecheck
5. Attach a suitable connector & hose pipe to the uppermost yellow vent-valve on the Zonecheck
6. Carefully crack open the yellow vent-valve
7. Keep yellow vent valve open until all air is expelled and only water is coming from the vent (may take up to 10 minutes)
8. Shut the yellow vent-valve
9. Remove the connector & hose pipe
10. Carefully re-insert and tighten the vent plug
11. Contact building management & let them know the testing is finished
12. Where applicable, re-establish the alarms and main fire pump

ADDRESSABLE FIRE PANEL CONNECTION DIAGRAM

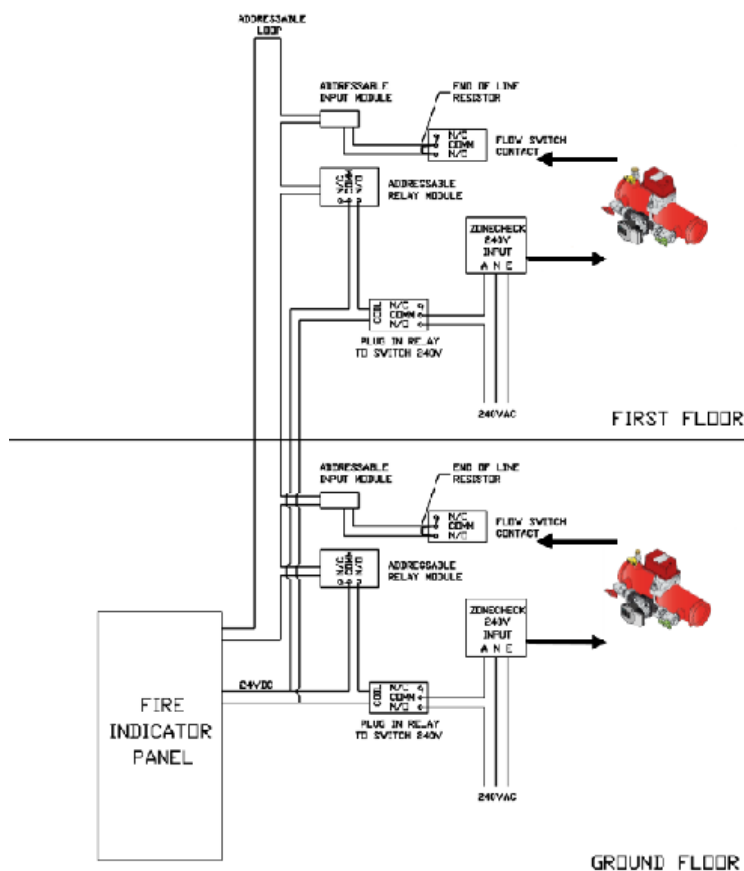

STANDARD 3030 CONNECTION DGP

DGP1

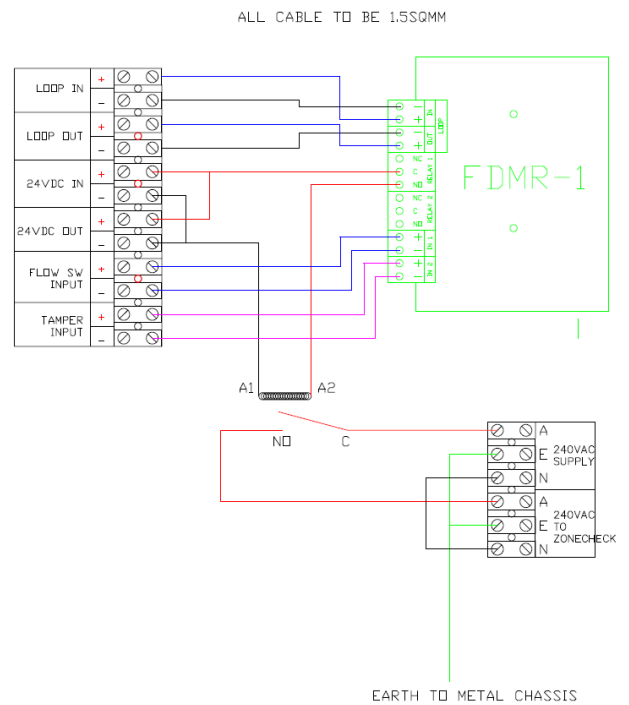
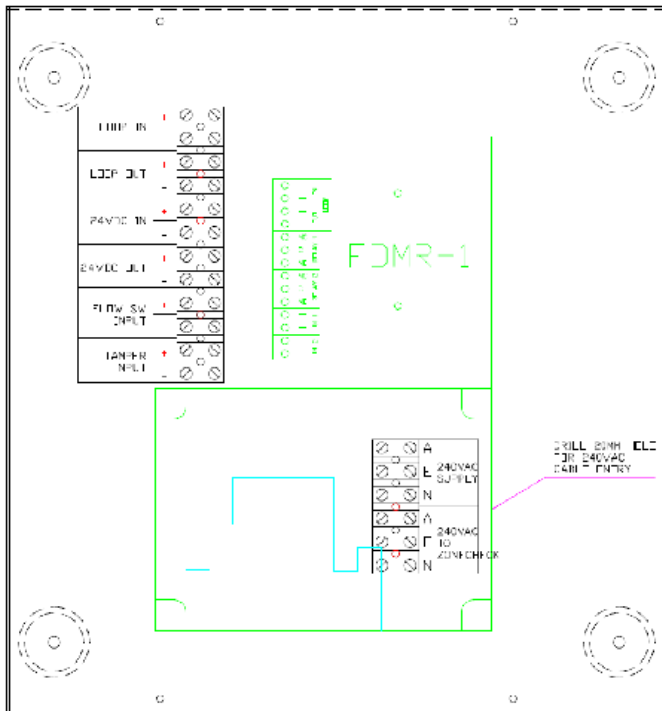

APPROVALS

- ✓ ActivFire certified - Listing No. afp-2363
- ✓ FM Approved*
- ✓ UL
- ✓ LPCB
- ✓ VdS

*Product is manufactured by Project Fire who hold the FM approval.