

#### FEATURES

- ✓ Up to 30 paging zones + 2 custom buttons
- ✓ Easy to use keypad layout
- ✓ Optional WIP control
- ✓ Priority paging
- ✓ Gooseneck or desktop microphone
- ✓ Connects to either ECS-16 or I2000 EWIS panels



#### PRODUCT DESCRIPTION

Each paging console gives selective zone paging for up to 30 zones. These zones do not need to be the same as evacuation zones. Programming of any combinations of amplifiers into paging zones can be done. Refer to the configuration printout for details of the current configuration.

If the system has more than 30 paging zones, then more than one paging console can be used at the same location to address the zones. Only one microphone is required.

#### TECHNICAL SPECIFICATIONS

Cabinet	Zinc sealed steel 1.6mm Powder coated charcoal grey (standard)
Dimensions	400mm W x 75mm H x 210mm D
Supply Voltage	24Vdc
Connections	Power, Comms, Audio

#### CONNECTION INFORMATION

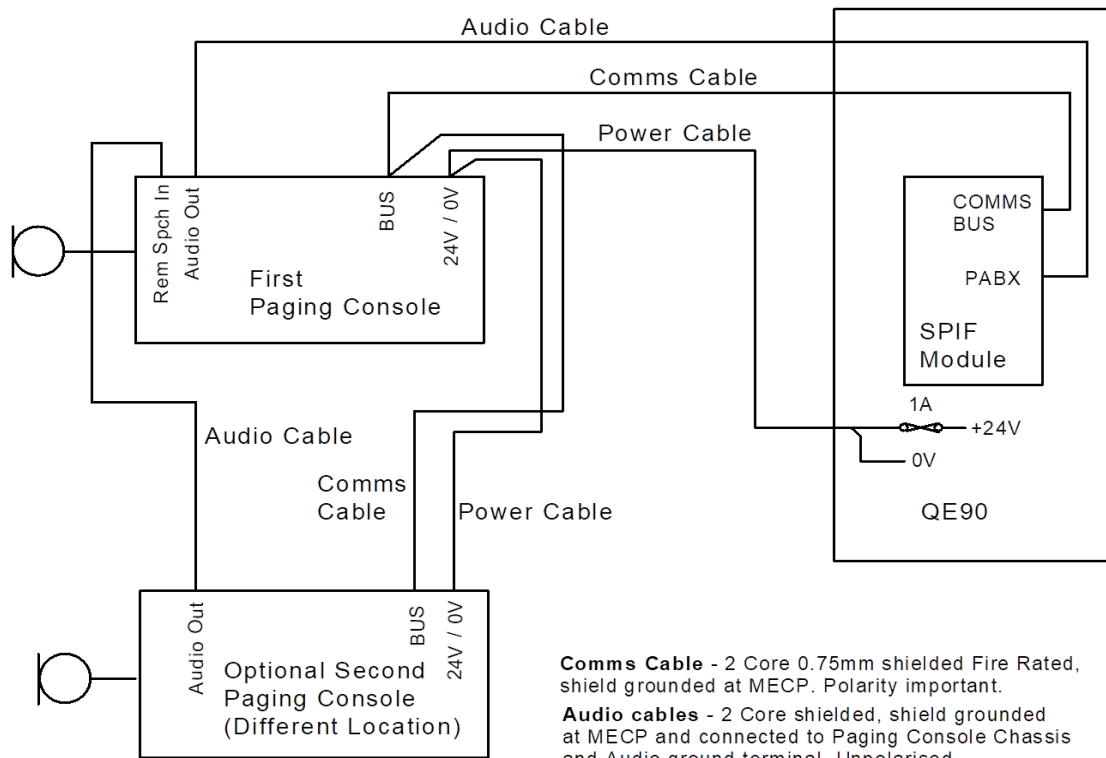

Note : First Paging Console has higher priority

**Comms Cable** - 2 Core 0.75mm shielded Fire Rated, shield grounded at MECP. Polarity important.

**Audio cables** - 2 Core shielded, shield grounded at MECP and connected to Paging Console Chassis and Audio ground terminal. Unpolarised.

**Power Cable** - 2 core 0.75mm. Polarity important

#### ORDERING INFORMATION

Product Code	Description
EWIS-PAG-CON	EWIS Paging Console

#### APPROVALS

- ✓ SSL approved to AS2220.1 - 1989
- ✓ ActivFire certified - Listing No. aft-1122